



NS2-25, NS2-32



NS2-25X, NS2-32X



NS2-32H



NS2-80

NS2 Manual Motor Starter

1. General

- 1.1 Certificates: SEMKO, CE, UkrSEPRO, EAC, RCC, UL;
- 1.2 Electric ratings: AC690V, 25A, 32A, 80A;
- 1.3 Standard: IEC/EN 60947-2, IEC60947-4-1

2. Type designation

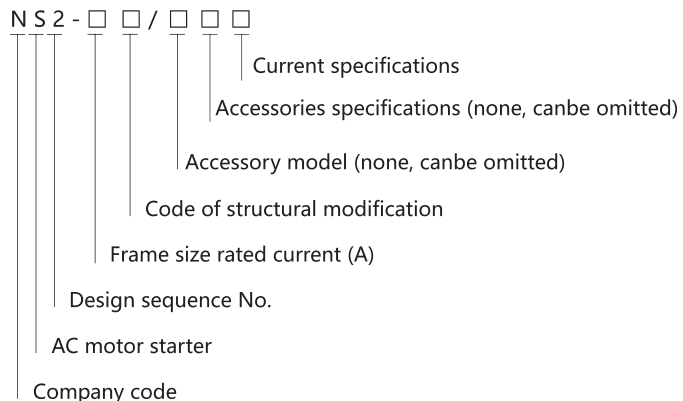

3. Operating conditions

- 3.1 Temperature: -5°C ~ +40°C,
average temperature in 24 hours not exceed +35°C
- 3.2 Altitude: not exceed 2000m
- 3.3 Air conditions:
At mounting site, relative humidity not exceed 50% at the max temperature of +40°C, higher relative humidity is allowable under lower temperature, for example, RH could be 90% at +20°C
- 3.4 Pollution grade: Grade III
- 3.5 Trip class:
10A(NS2-25, NS2-25X, NS2-32, NS2-32X, NS2-32H, NS2-80)
- 3.6 Rated operational system:
Continuous operational system
- 3.7 Mounting conditions:
The inclination between the mounting plane and the vertical plane shall not exceed 5°
The product shall be installed and operated at a place without obvious shake, impact and vibration.

4. Technical data

Series No.	Multiple of setting current	Initial status	Time	Expected results	Ambient temperature
1	1.05	Cold status	$t \geq 2h$	Non-tripping	$+20^{\circ}\text{C} \pm 2^{\circ}\text{C}$
2	1.20	Heat status (right after test.1)	$t < 2h$	Tripping	$+20^{\circ}\text{C} \pm 2^{\circ}\text{C}$
3	1.50	Heat status (right after test.1)	Tripping class 10A $t < 2\text{min}$ 10 $t < 4\text{min}$	Tripping	$+20^{\circ}\text{C} \pm 2^{\circ}\text{C}$
4	7.20	Cold status	Tripping class 10A $2s < t \leq 10s$ 10 $4s < t \leq 10s$	Tripping	$+20^{\circ}\text{C} \pm 2^{\circ}\text{C}$

Phase failure protection properties

Series No.	Multiple of setting current		Initial status	Time	Expected results	Ambient temperature
	Any 2 phases	The other phase				
1	1.0	0.9	Cold status	$t \geq 2h$	Non-tripping	$+20^{\circ}\text{C} \pm 2^{\circ}\text{C}$
2	1.15	0	Heat status (right after test.1)	$t < 2h$	Tripping	$+20^{\circ}\text{C} \pm 2^{\circ}\text{C}$

Temperature compensation properties

Series No.	Multiple of setting current	Initial status	Time	Expected results	Ambient temperature
1	1.0	Cold status	$t \geq 2h$	Non-tripping	$+40^{\circ}\text{C} \pm 2^{\circ}\text{C}$
2	1.2	Heat status (right after test.1)	$t < 2h$	Tripping	$+40^{\circ}\text{C} \pm 2^{\circ}\text{C}$
3	1.5	Heat status (through 1.0 times rated current ,after thermal equilibrium is reached)	$t < 2\text{min}$	Tripping	$+40^{\circ}\text{C} \pm 2^{\circ}\text{C}$
4	1.05	Cold status	$t \geq 2h$	Non-tripping	$-5^{\circ}\text{C} \pm 2^{\circ}\text{C}$
5	1.3	Heat status (right after test.3)	$t < 2h$	Tripping	$-5^{\circ}\text{C} \pm 2^{\circ}\text{C}$
6	1.5	Heat status (through 1.0 times rated current ,after thermal equilibrium is reached)	$t < 4\text{min}$	Tripping	$-5^{\circ}\text{C} \pm 2^{\circ}\text{C}$

4.2 Technical parameters

Type	Rated current of release $I_n(\Delta)$	Setting current regulation range (A)	Rated ultimate short-circuit breaking I_{cu} , Rated service short-circuit breaking capacity I_{cs}				Arcing distance (mm)
			400/415V		690V		
			I_{cu}	I_{cs}	I_{cu}	I_{cs}	
NS2-25(X)	0.16	0.1 ~ 0.16	100	100	100	100	40
NS2-25(X)	0.25	0.16 ~ 0.25	100	100	100	100	40
NS2-25(X)	0.4	0.25 ~ 0.4	100	100	100	100	40
NS2-25(X)	0.63	0.4 ~ 0.63	100	100	100	100	40
NS2-25(X)	1	0.63 ~ 1	100	100	100	100	40
NS2-25(X)	1.6	1 ~ 1.6	100	100	100	100	40
NS2-25(X)	2.5	1.6 ~ 2.5	100	100	3	2.25	40
NS2-25(X)	4	2.5 ~ 4	100	100	3	2.25	40
NS2-25(X)	6.3	4 ~ 6.3	100	100	3	2.25	40
NS2-25(X)	10	6 ~ 10	100	100	3	2.25	40
NS2-25(X)	14	9 ~ 14	15	7.5	3	2.25	40
NS2-25(X)	18	13 ~ 18	15	7.5	3	2.25	40
NS2-25(X)	23	17 ~ 23	15	6	3	2.25	40
NS2-25(X)	25	20 ~ 25	15	6	3	2.25	40
NS2-32(X)	32	24 ~ 32	10	5	3	2.25	40
NS2-32H	0.16	0.1 ~ 0.16	100	100	100	100	40
NS2-32H	0.25	0.16 ~ 0.25	100	100	100	100	40
NS2-32H	0.4	0.25 ~ 0.4	100	100	100	100	40
NS2-32H	0.63	0.4 ~ 0.63	100	100	100	100	40
NS2-32H	1	0.63 ~ 1	100	100	100	100	40
NS2-32H	1.6	1 ~ 1.6	100	100	100	100	40
NS2-32H	2.5	1.6 ~ 2.5	100	100	4	4	40
NS2-32H	4	2.5 ~ 4	100	100	4	4	40
NS2-32H	6.3	4 ~ 6.3	100	100	4	4	40
NS2-32H	10	6 ~ 10	100	100	4	4	40
NS2-32H	14	9 ~ 14	50	25	4	4	40
NS2-32H	18	13 ~ 18	50	25	4	4	40
NS2-32H	23	17 ~ 23	50	25	4	4	40
NS2-32H	25	20 ~ 25	50	25	4	4	40
NS2-32H	32	24 ~ 32	50	25	4	4	40
NS2-80	25	20~25	50	17.5	4	2	50
NS2-80	32	23~32	50	17.5	4	2	50
NS2-80	40	30~40	50	17.5	4	2	50
NS2-80	50	37~50	50	17.5	4	2	50
NS2-80	65	48~65	50	17.5	4	2	50
NS2-80	80	63~80	50	17.5	4	2	50

4.2.1 Rated power of three phase motor controlled by starter

Type	Rated current of release In(A)	Setting current regulation range (A)	Standard Rated Power Three Phase Motor (kW)					
			AC-3, 50Hz/60Hz					
			230/240V	400V	415V	440V	500V	690V
NS2-25(X), NS2-32H	0.16	0.1-0.16	-	-	-	-	-	-
NS2-25(X), NS2-32H	0.25	0.16-0.25	-	-	-	-	-	-
NS2-25(X), NS2-32H	0.4	0.25-0.4	-	-	-	-	-	-
NS2-25(X), NS2-32H	0.63	0.4-0.63	-	-	-	-	-	0.37
NS2-25(X), NS2-32H	1	0.63-1	-	-	-	0.37	0.37	0.55
NS2-25(X), NS2-32H	1.6	1-1.6	-	0.37	-	0.55	0.75	1.1
NS2-25(X), NS2-32H	2.5	1.6-2.5	0.37	0.75	0.75	1.1	1.1	1.5
NS2-25(X), NS2-32H	4	2.5-4	0.75	1.5	1.5	1.5	2.2	3
NS2-25(X), NS2-32H	6.3	4-6.3	1.1	2.2	2.2	3	3.7	4
NS2-25(X), NS2-32H	10	6-10	2.2	4	4	4	5.5	7.5
NS2-25(X), NS2-32H	14	9-14	3	5.5	5.5	7.5	7.5	9
NS2-25(X), NS2-32H	18	13-18	4	7.5	9	9	9	11
NS2-25(X), NS2-32H	23	17-23	5.5	11	11	11	11	15
NS2-25(X), NS2-32H	25	20-25	5.5	11	11	11	15	18.5
NS2-32(X), NS2-32H3	22	4-32	7.5	15	15	151	8.52	5

4.3 Setting value of instantaneous electromagnetic tripping current of starter

Type	Rated current of release I_n (A)	Regulating range of setting current of thermal element(A)	Current setting value of instantaneous electromagnetic release I_r (A)
NS2-25(X)	0.16	0.1-0.16	1.5
	0.25	0.16-0.25	2.4
	0.4	0.25-0.4	5
	0.63	0.4-0.63	8
	1	0.63-1	13
	1.6	1-1.6	22.5
	2.5	1.6-2.5	33.5
N2S3-2H	4	2.5-4	51
	6.3	4-6.3	78
	10	6-10	138
	14	9-14	170
	18	13-18	223
	23	17-23	327
	25	20-25	327
NS2-32(X), N2S3-2H	32	24-32	416
	25	20-25	350
NS2-80	32	23-32	448
	40	30-40	560
	50	37-50	700
	65	48-65	910
	80	63-80	1120

4.3.1 Action characteristics of instantaneous electromagnetic trip of starter

Test current	Initial state	Set time	Expected results	Ambient air temperature
0.8I _r	Cold state	$t \geq 0.2s$	No trip	+20°C ±5°C
1.2I _r	Cold state	$t < 0.2s$	Trip	+20°C ±5°C

4.3.1 Action characteristics of instantaneous electromagnetic trip of starter

Test current	Initial state	Set time	Expected results	Ambient air temperature
0.8I _r	Cold state	$t \geq 0.2s$	No trip	+20°C ±5°C
1.2I _r	Cold state	$t < 0.2s$	Trip	+20°C ±5°C

4.4 Selection of backup fuse

When the expected short-circuit current of the installation site is greater than the rated limit short-circuit breaking capacity of the starter, the type and melt current specification of the backup short-circuit protection fuse shall be provided. For example, gG type fuse can be selected.

Type	Rated current of release I _n (A)	Setting current regulation range (A)	Current rating of fuse-link of back-up fuse, which I _{cc} > I _{cu}									
			230/240V		400/415V		440V		500V		690V	
			aM A	gL/gG A	aM A	gL/gG A	aM A	gL/gG A	aM A	gL/gG A	aM A	gL/gG A
NS2-25(X)	0.16	0.1-0.16	*	*	*	*	*	*	*	*	*	*
NS2-25(X)	0.25	0.16-0.25	*	*	*	*	*	*	*	*	*	*
NS2-25(X)	0.4	0.25-0.4	*	*	*	*	*	*	*	*	*	*
NS2-25(X)	0.63	0.4-0.63	*	*	*	*	*	*	*	*	*	*
NS2-25(X)	1	0.63-1	*	*	*	*	*	*	*	*	*	*
NS2-25(X)	1.6	1-1.6	*	*	*	*	*	*	*	*	*	*
NS2-25(X)	2.5	1.6-2.5	*	*	*	*	*	*	*	*	16	20
NS2-25(X)	4	2.5-4	*	*	*	*	*	*	*	*	25	32
NS2-25(X)	6.3	4-6.3	*	*	*	*	50	63	50	63	32	40
NS2-25(X)	10	6-10	*	*	*	*	50	63	50	63	32	40
NS2-25(X)	14	9-14	*	*	63	80	50	63	50	63	40	50
NS2-25(X)	18	13-18	*	*	63	80	50	63	50	63	40	50
NS2-25(X)	23	17-23	80	100	80	100	63	80	50	63	40	50
NS2-25(X)	25	20-25	80	100	80	100	63	80	50	63	40	50
NS2-32(X)	32	24-32	80	100	80	100	63	80	50	63	40	50
NS2-32H	0.16	0.1-0.16	*	*	*	*	*	*	*	*	*	*
NS2-32H	0.25	0.16-0.25	*	*	*	*	*	*	*	*	*	*
NS2-32H	0.4	0.25-0.4	*	*	*	*	*	*	*	*	*	*
NS2-32H	0.63	0.4-0.63	*	*	*	*	*	*	*	*	*	*
NS2-32H	1	0.63-1	*	*	*	*	*	*	*	*	*	*
NS2-32H	1.6	1-1.6	*	*	*	*	*	*	*	*	*	*
NS2-32H	2.5	1.6-2.5	*	*	*	*	*	*	*	*	20	25
NS2-32H	4	2.5-4	*	*	*	*	*	*	*	*	25	32
NS2-32H	6.3	4-6.3	*	*	*	*	*	*	*	*	40	50
NS2-32H	10	6-10	*	*	*	*	*	*	50	63	40	50
NS2-32H	14	9-14	*	*	*	*	50	63	50	63	50	63
NS2-32H	18	13-18	*	*	100	125	63	80	50	63	50	63
NS2-32H	23	17-23	*	*	100	125	80	100	50	63	50	63
NS2-32H	25	20-25	*	*	100	125	80	100	50	63	50	63
NS2-32H	32	24-32	*	*	100	125	80	100	50	63	50	63
NS2-80	25	20-25	-	-	250	315	-	-	-	-	160	200
NS2-80	32	23-32	-	-	250	315	-	-	-	-	160	200
NS2-80	40	30-40	-	-	250	315	-	-	-	-	160	200
NS2-80	50	37-50	-	-	315	400	-	-	-	-	200	250
NS2-80	65	48-65	-	-	315	400	-	-	-	-	200	250



5. Other

5.1 Starters accessories

5.1.1 Type, model and specifications of accessories (see Table 10).

Description of accessories	Accessories Model				Accessories Specifications
	NS2-25, NS2-32 applies	NS2-25X, NS2-32X applies	NS2-32H applies	NS2-80 applies	
Undervoltage release	NS2-UV110	NS2-UV110	NS2-UV110	NS2-UV110	110~115V, 50Hz; 127V, 60Hz
	NS2-UV220	NS2-UV220	NS2-UV220	NS2-UV220	220~240V, 50Hz
	NS2-UV380	NS2-UV380	NS2-UV380	NS2-UV380	380~400V, 50Hz; 440V, 60Hz
Shunt release	NS2-SH110	NS2-SH110	NS2-SH110	NS2-SH110	110~115V, 50Hz; 127V, 60Hz
	NS2-SH220	NS2-SH220	NS2-SH220	NS2-SH220	220~240V, 50Hz
	NS2-SH380	NS2-SH380	NS2-SH380	NS2-SH380	380~400V, 50Hz; 440V, 60Hz
Instantaneous auxiliary contact (front hanging)	NS2-AE20	NS2-AE20	NS2-AE20	NS2-AE20	2NO
	NS2-AE11	NS2-AE11	NS2-AE11	NS2-AE11	1NO+1NC
Instantaneous auxiliary contact (side hanging)	NS2-AU20	NS2-AU20	NS2-AU20	NS2-AU20(NS2-80)	2NO
	NS2-AU11	NS2-AU11	NS2-AU11	NS2-AU11(NS2-80)	1NO+1NC
Fault signal contact and instantaneous auxiliary contact	NS2-FA0110	NS2-FA0110	NS2-FA0110	-	1NC+1NO
	NS2-FA0101	NS2-FA0101	NS2-FA0101	-	1NC+1NC
	NS2-FA1010	NS2-FA1010	NS2-FA1010	-	1NO+1NO
	NS2-FA1001	NS2-FA1001	NS2-FA1001	-	1NO+1NC
Waterproof mounting box	NS2-MC	WPB-1	-	-	-
Mounting box with emergency stop button	NS2-MC01	-	-	-	-

5.1.2 Undervoltage trip device

NS2-UV110, UV220, UV380'S, performance:

- a. Rated insulation voltage U_i (V): 690.
- b. Operating characteristics: When the voltage drops to 70% and 35% of the rated voltage range, undervoltage trip device shall act;

Undervoltage trip device in the power supply voltage is less than 35% of the rated voltage of the trip device, the undervoltage trip device should be able to prevent the starter from closing;

when the power supply voltage is equal to or greater than 85% of the rated voltage of the trip device, the undervoltage trip device should guarantee closure of the starter.



NS2-UV

5.1.3 The characteristics of the shunt trip

NS2-SH110, SH220, SH380:

- a. Rated insulation voltage U_i (V): 690.
- b. Operating characteristics: the operating voltage range of the shunt trip device is rated working voltage of 70% ~ 110%.



NS2-SH

5.1.4 Characteristics of the instantaneous auxiliary contact NS2-

Ae20, AE11 (front hanging)

- a. rated insulation voltage U_i (V): 250;
- b. agreed thermal current I_{th} (A): 2.5;
- c. type, rated voltage and rated operating current (see Table 11) of instantaneous auxiliary contacts.



NS2-AE

Table 11

Utilization category	AC-15				DC-13		
	24	48	110/127	230/240	24	48	60
Rated operating voltage U_e (V)	24	48	110/127	230/240	24	48	60
Rated operating current I_e (A)	2	1.25	1	0.5	1	0.3	0.15
Normal operating power P (W)	48	60	127	120	24	15	9



5.1.5 Instantaneous auxiliary contact NS2-AU20, AU11

performance (side hanging):

- a. rated insulation voltage U_i (V): 690;?
- b. agreed thermal current I_{th} (A): 6;?
- c. type, rated voltage and rated operating current of the instantaneous auxiliary contacts (see Table 12).



Utilization category	AC-15							DC-13				
Rated operating voltage U_e (V)	48	110/127	230/240	380/415	440	500	690	24	48	60	110	220
Rated operating current I_e (A)	6	4.5	3.3	2.2	1.5	1	0.6	6	5	3	1.3	0.5
Normal operating power P (W)	300	500	720	850	650	500	400	140	240	180	140	120

5.1.6 Characteristics of the fault signal contact and instantaneous auxiliary contact NS2-FA:?

Fault signal contact and instantaneous auxiliary contact NS2-FA, consist of the fault signal contact and instantaneous auxiliary contact. They have different use types and characteristics.

- a. rated insulation voltage U_i (V): 690;
- b. agreed thermal currents of instantaneous auxiliary contacts: I_{th} (A) : 6, agreed thermal current of fault signal contacts I_{th} (A): 2.5;
- c. the use type, rated voltage and rated work?current (see Table 12) of the instantaneous auxiliary contact same as the NS2-AU instantaneous auxiliary contact; the use type, rated voltage and rated operating current (see Table 13) of the fault signal contacts.



Utilization category	AC-14				DC-13		
Rated operating voltage U_e (V)	24	48	110/127	230/240	24	48	60
Rated operating current I_e (A)	1.5	1	0.5	0.3	1	0.3	0.15
Normal operating power P (W)	36	48	72	72	24	15	9
Operating performance (time)	1000	1000	1000	1000	1000	1000	1000

5.1.7 Non-normal making and breaking capacity (see Table 14) of fault signal contact and instantaneous auxiliary contact.

Use type	Connection		Disconnection				On-off operation cycles and operating frequency		
	I/I_e	U/U_e	$\cos\Phi$ or T0.95	I/I_e	U/U_e	$\cos\Phi$ or T0.95	Operating cycles	Operating cycles per minutes	Energize Time
AC-14	6	1.1	0.7	6	1.1	0.7	10	2	0.05
AC-15	10	1.1	0.3	10	1.1	0.3	10	2	0.05
DC-13	1.1	1.1	6Pe	1.1	1.1	6Pe	10	2	0.05

Note: $P_e \geq 50W$, T0.95 upper limit $\approx 6P_e \leq 300ms$.

5.1.8 Mounting box (NS2-MC, NS2-MC01)



NS2-MC Waterproof installation box

IP55



NS2-MC01 Installation box with emergency stop button

IP55



WPB-1 Waterproof installation box

IP55

6. Overall and mounting dimension (mm)

NS2-25, NS2-32

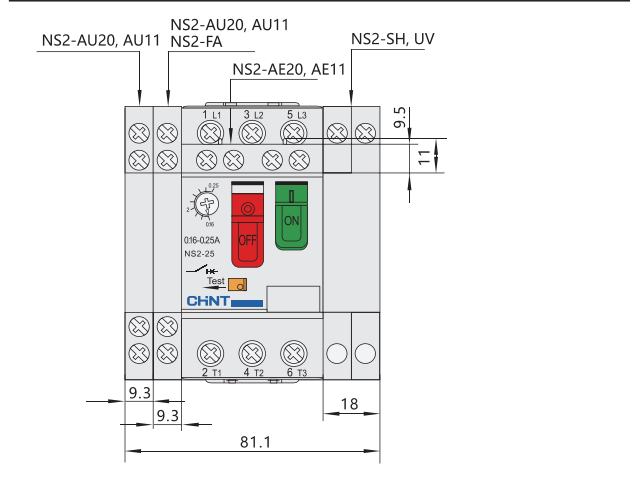

NS2-80

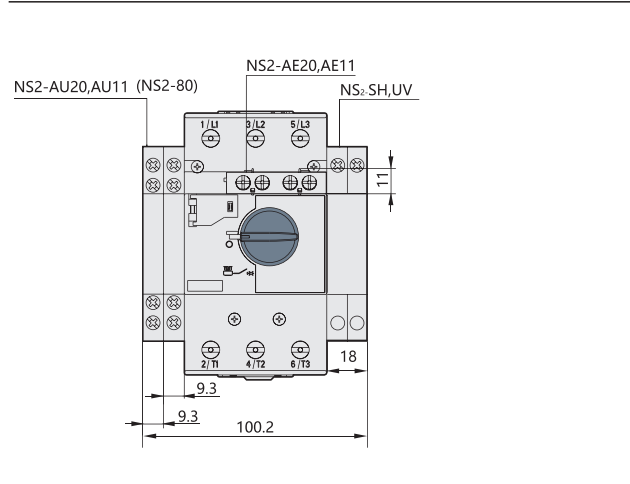

NS2-25X, NS2-32X

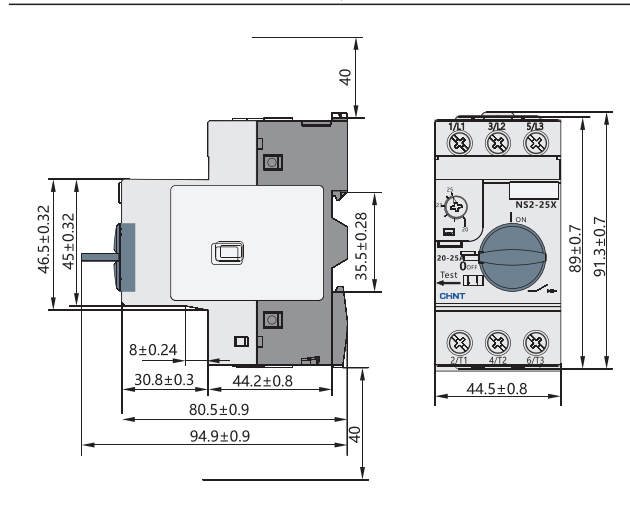

NS2-25X, NS2-32X, NS2-32H

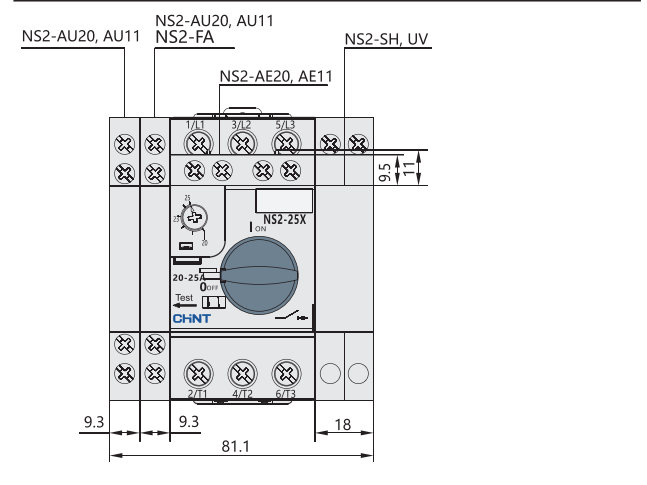

NS2-25, NS2-32

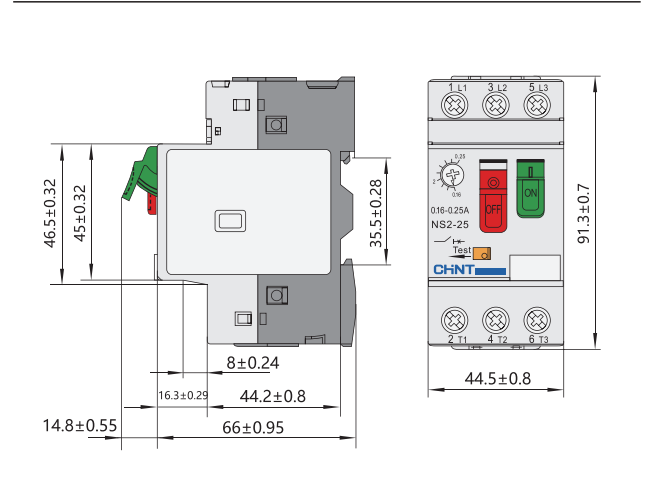

NS2-32H

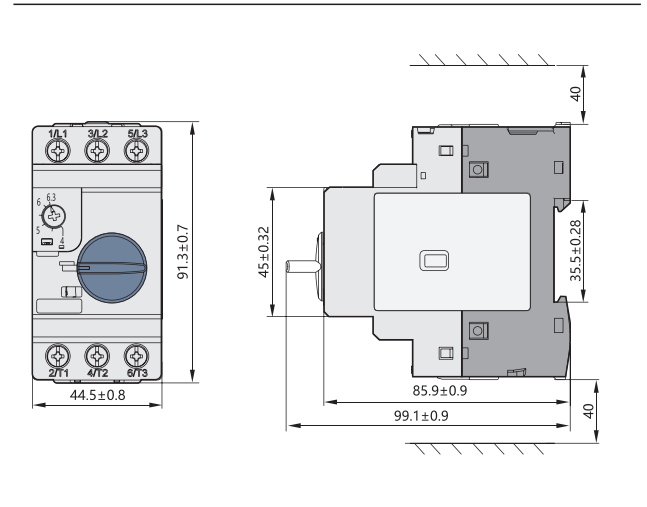

NS2-80B

NS2-80

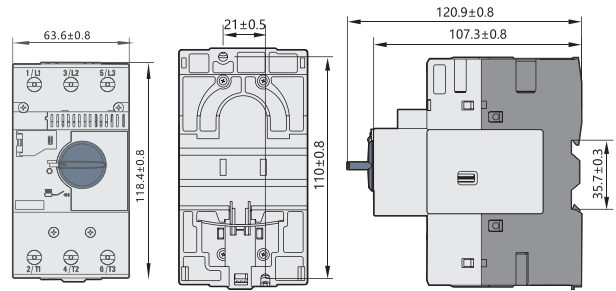
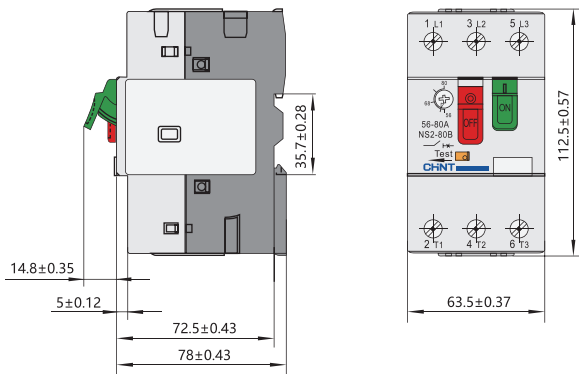

NS2-MC

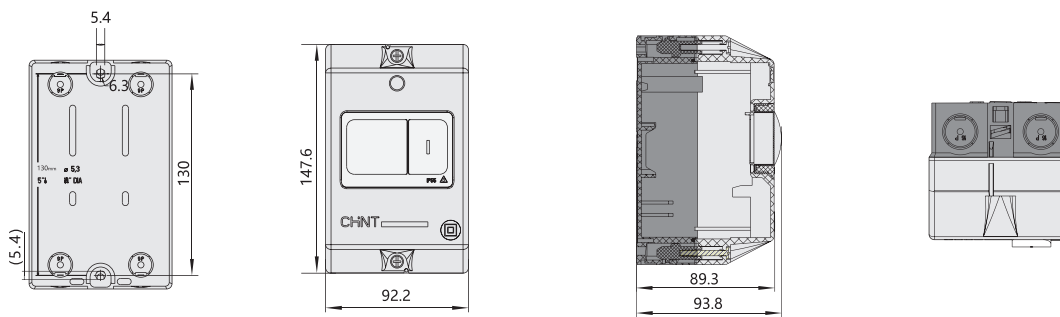

NS2-MC01

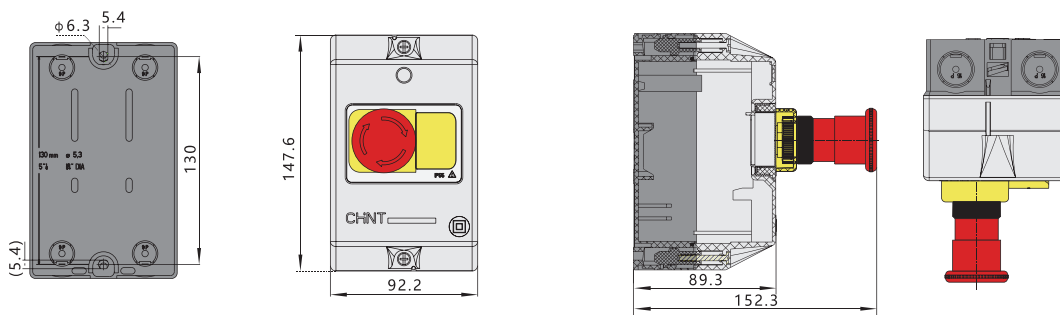

WPB-1

